



40 ton at work



35 ton crane travelling through steep terrain

Wm. O'BRIEN

WHERE O'BRIEN GOES - PROSPERITY FOLLOWS

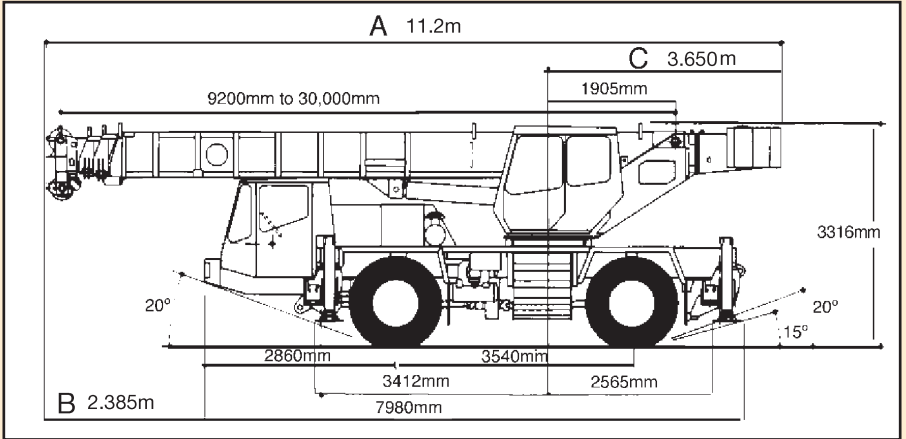

SIDE VIEW

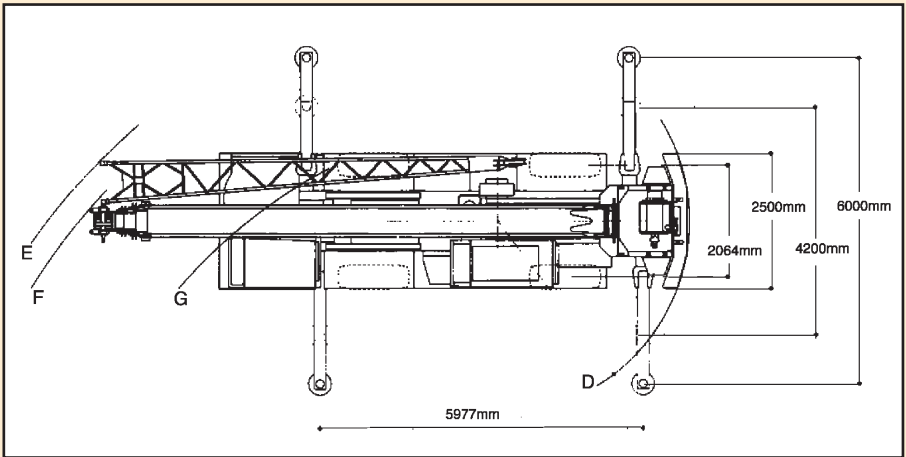

CRANE PLAN



DON'T RISK IT - LET O'BRIEN LIFT IT

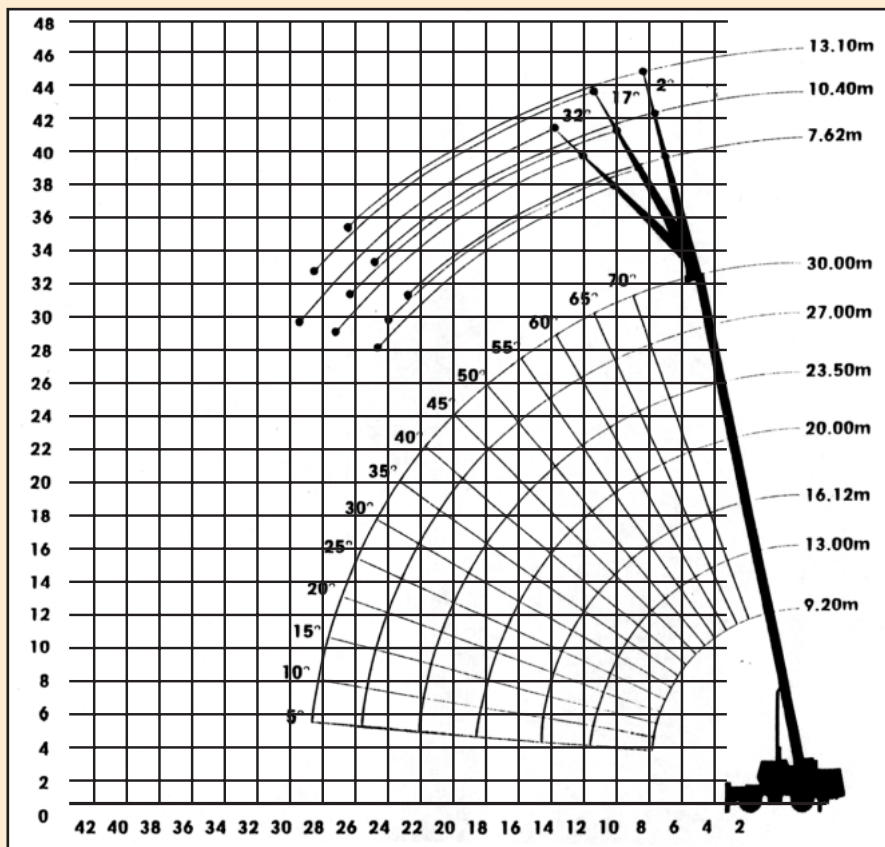

WORKING RANGE



WHERE O'BRIEN GOES - PROSPERITY FOLLOWS

| Radius | Main boom lifting capacities on fully extended outriggers - 360° Main Boom Length (m) | | | | | | | Main boom lifting capacities on partially extended outriggers - 360° Main Boom Length (m) | | | | | | |
|----------|--|-------------|--------------|-------------|--------------|-------------|--------------|--|--------------|--------------|--------------|--------------|--------------|--------------|
| | 9,20 | 13,0 | 16,12 | 20,0 | 23,50 | 27,0 | 30,00 | 9,20 | 13,00 | 16,12 | 20,00 | 23,50 | 27,00 | 30,00 |
| M | 9,20 | 13,0 | 16,12 | 20,0 | 23,50 | 27,0 | 30,00 | 9,20 | 13,00 | 16,12 | 20,00 | 23,50 | 27,00 | 30,00 |
| 2.5 | 35,00 | | | | | | | | | | | | | |
| 3.0 | 30,00 | 24,40 | 17,15 | | | | | 21,00 | 20,50 | 17,15 | | | | |
| 3.5 | 24,15 | 22,55 | 17,15 | | | | | 18,50 | 17,65 | 17,15 | | | | |
| 4.0 | 21,35 | 20,75 | 17,15 | 13,75 | | | | 16,40 | 15,80 | 15,60 | 13,75 | | | |
| 4.5 | 18,65 | 18,40 | 16,65 | 13,75 | | | | 14,65 | 14,25 | 14,00 | 13,75 | | | |
| 5.0 | 16,50 | 16,25 | 15,55 | 13,30 | 12,05 | | | 13,00 | 12,80 | 12,60 | 12,65 | 12,05 | | |
| 6.0 | 13,25 | 13,00 | 12,85 | 11,80 | 10,85 | 9,40 | 7,50@ | 9,90 | 9,60 | 9,45 | 9,60 | 9,50 | 9,30 | 7,00@ |
| 7.0 | 10,90 | 10,65 | 10,55 | 10,65 | 9,80 | 8,60 | 7,25M | 7,35 | 7,10 | 6,95 | 7,45 | 7,55 | 7,45 | 7,25M |
| 8.0 | | 8,90 | 8,80 | 9,20 | 8,90 | 7,85 | 7,00 | | 5,40 | 5,30 | 5,75 | 6,00 | 6,10 | 6,05 |
| 9.0 | | 7,10 | 7,00 | 7,45 | 7,75 | 7,30 | 6,45 | | 4,20 | 4,10 | 4,55 | 4,80 | 5,00 | 5,05 |
| 10.0 | | 5,75 | 5,65 | 6,10 | 6,40 | 6,60 | 5,95 | | 3,30 | 3,20 | 3,60 | 3,90 | 4,10 | 4,20 |
| 12.0 | | | 3,80 | 4,25 | 4,50 | 4,70 | 4,85 | | | 1,95 | 2,35 | 2,60 | 2,80 | 2,90 |
| 14.0 | | | 2,60 | 3,00 | 3,30 | 3,45 | 3,60 | | | 1,05 | 1,50 | 1,75 | 1,90 | 2,05 |
| 16.0 | | | | 2,15 | 2,40 | 2,60 | 2,70 | | | | 0,85 | 1,10 | 1,30 | 1,40 |
| 18.0 | | | | | 1,75 | 1,95 | 2,05 | | | | | 0,65 | 0,80 | 0,95 |
| 20.0 | | | | | 1,25 | 1,40 | 1,55 | | | | | | 0,45 | 0,55 |
| 22.0 | | | | | | 1,00 | 1,15 | | | | | | | |
| 24.0 | | | | | | 0,70 | 0,80 | | | | | | | |
| 26.0 | | | | | | | 0,55 | | | | | | | |
| 28.00 | | | | | | | | | | | | | | |
| 30.00 | | | | | | | | | | | | | | |

| Radius | Main boom length (m) | | | | | | | | | | | | | | |
|--------|----------------------|------|------|--------------|------|-------|--------------|-------|------|---------------|------|------|---------------|-------|------|
| | 23.50m | | | 27.00m | | | 30.00m | | | 10.40m length | | | 13.10m length | | |
| | 7.62m length | | | 7.62m length | | | 7.62m length | | | 10.40m length | | | 13.10m length | | |
| | Offset | | | Offset | | | Offset | | | Offset | | | Offset | | |
| M | 2° | 17° | 32° | 2° | 17° | 32° | 2° | 17° | 32° | 2° | 17° | 32° | 2° | 17° | 32° |
| 7.00 | 5.20 | | | | | | | | | | | | | | |
| 8.00 | 4.85 | | | 4.40 | | | | | | | | | | | |
| 9.00 | 4.50 | 3.15 | | 4.25 | | 2.35@ | 3.10 | 2.70@ | | | | | | 1.55@ | |
| 10.00 | 4.25 | 3.00 | 2.40 | 4.10 | 3.15 | 10.7M | 2.90 | 10.4M | | 2.00 | | | 9.85M | | |
| 12.00 | 3.75 | 2.80 | 2.20 | 3.80 | 2.90 | 2.30 | 2.60 | 2.55 | 2.30 | 1.85 | 1.70 | | 1.50 | | |
| 14.00 | 3.40 | 2.55 | 2.05 | 3.40 | 2.70 | 2.15 | 2.35 | 2.30 | 2.15 | 1.65 | 1.60 | 1.45 | 1.30 | 1.25 | |
| 16.00 | 2.65 | 2.35 | 1.90 | 2.70 | 2.50 | 2.00 | 2.10 | 2.05 | 2.05 | 1.45 | 1.40 | 1.35 | 1.15 | 1.15 | 1.00 |
| 18.00 | 1.95 | 2.10 | 1.80 | 2.00 | 2.20 | 1.90 | 1.90 | 1.85 | 1.95 | 1.30 | 1.30 | 1.20 | 1.05 | 1.05 | 0.98 |
| 20.00 | 1.45 | 1.55 | 1.65 | 1.50 | 1.65 | 1.75 | 1.55 | 1.70 | 1.80 | 1.15 | 1.15 | 1.10 | 0.95 | 0.95 | 0.95 |
| 22.00 | 1.00 | 1.10 | 1.20 | 1.05 | 1.20 | 1.30 | 1.10 | 1.25 | 1.35 | 0.95 | 1.05 | 0.95 | 0.80 | 0.80 | 0.85 |
| 24.00 | 0.70 | 0.75 | 0.80 | 0.75 | 0.85 | 0.90 | 0.75 | 0.85 | 0.95 | 0.85 | 0.90 | 0.90 | 0.70 | 0.70 | 0.80 |
| 26.00 | 0.40 | 0.45 | 0.45 | 0.45 | 0.55 | 0.60 | 0.50 | 0.60 | 0.65 | 0.65 | 0.80 | 0.85 | 0.55 | 0.65 | 0.75 |
| 28.00 | | | | | | | | | 0.35 | 0.40 | 0.55 | 0.60 | 0.50 | 0.50 | 0.65 |
| 30.00 | | | | | | | | | | | | 0.35 | 0.35 | 0.45 | 0.55 |
| 32.00 | | | | | | | | | | | | | | | 0.35 |



DON'T RISK IT - LET O'BRIEN LIFT IT